

Electrode Relay / Water Detector Relay / Rod and Floor Electrodes

KSR KUEBLER AG Data sheet Electrode Relay/Water Detector Relay

Applications

- Chemical industry, petrochemical, offshore
- ship building, machine building
- Power plants
- Pharmaceutical , Food an beverage industry, water purification, environmental industry

Special features

- protected low voltage control circuit to VDE 0100 part 410
- Min-Max-Control
- open circuit current / closed circuit current – user selectable



Description Electrode relay

KSR Electrode relays type ER230 and ER24 operate on the conductive measurement principle and can be used in conjunction with KSR Rod electrodes to monitor and control liquid levels of electrically conductive media such as water, caustic solutions or acids. They have a protected low voltage control circuit to VDE 0100 part 410.

Description Water detector relay

KSR Water detector relays type WW230 and WW24 operate on the conductive measurement principle. In conjunction with KSR Floor electrodes they can be used to monitor water ingress into rooms and areas caused by burst pipes or leaking vessels etc.

Dimensions

W 20 mm
H 105 mm
D 115 mm



Dimension

B 20 mm
H 105 mm
T 115 mm



Electrode Relay Type ER230 and ER24

General Description

KSR Electrode relays type ER230 and ER24 operate on the conductive measurement principle and can be used in conjunction with KSR Rod electrodes to monitor and control liquid levels of electrically conductive media such as water, caustic solutions or acids. They have a protected low voltage control circuit to VDE 0100 part 410.

The electrode relays provide an AC measuring voltage to the electrodes and react to the small alternating current at the electrode tip, generated upon contact with the conductive medium. The controllers are voltage and temperature stabilised and guarantee a defined switch behaviour. A holding contact allows the units to be used as min-max controllers. As conductivity can vary from liquid to liquid, the response sensitivity of the relay units is adjustable. Via the relay outputs, the switch signals can be forwarded to other evaluating circuits or instruments. Power supply/output, power supply/input and input/output are galvanically isolated to DIN 106, rated insulation voltage of 253V.

Technical features

Open circuit current principle:

In the open circuit current principle the relay energises when the liquid reaches the electrode.

Closed circuit current principle :

In the closed circuit current principle the relay energises immediately on power up. It de-energises, when the liquid reaches the electrode.

- protected low voltage control circuit to VDE 0100 part 410
- Min-Max-Control
- open circuit current / closed circuit current – user selectable

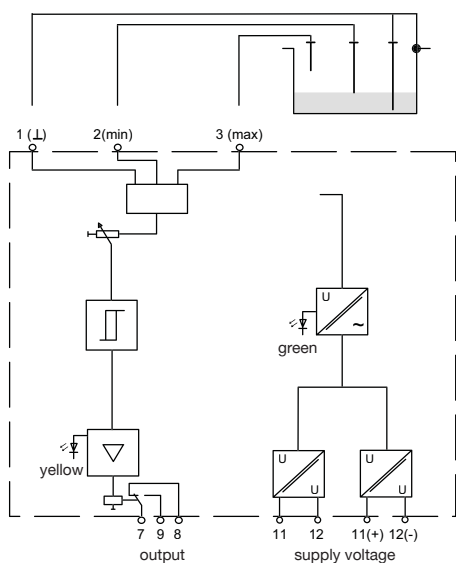

Selection of operating mode output relay

detail front panel	input	output				
	<table border="1"> <tr><td>1</td><td>3</td></tr> <tr><td>↑</td><td>↑</td></tr> </table> 1 -Signal	1	3	↑	↑	Relay energised
1	3					
↑	↑					
	<table border="1"> <tr><td>1</td><td>3</td></tr> <tr><td>↑</td><td>↓</td></tr> </table> 0 -Signal	1	3	↑	↓	Relay de-energised
1	3					
↑	↓					

detail front panel	input	output				
	<table border="1"> <tr><td>1</td><td>3</td></tr> <tr><td>↓</td><td>↓</td></tr> </table> 0 -Signal	1	3	↓	↓	Relay energised
1	3					
↓	↓					
	<table border="1"> <tr><td>1</td><td>3</td></tr> <tr><td>↓</td><td>↑</td></tr> </table> 1 -Signal	1	3	↓	↑	Relay de-energised
1	3					
↓	↑					

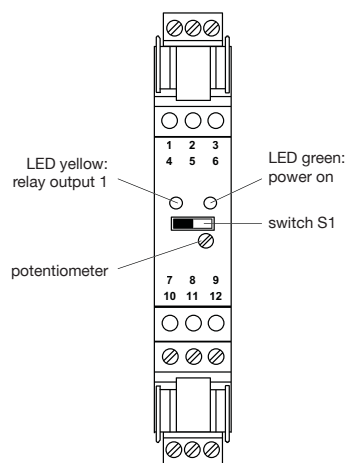

Electrode Relay

Type ER230 and ER24

Technical data		ER230	ER24
Supply			
supply voltage	terminals 11(+), 12(-)	230 V AC, 48 Hz ... 62 Hz	24 V DC
power consumption		≤ 0,8 W	≤ 0,8W
Input/control circuit	terminals 1, 2 and 3	1 (mass/ground) ; 2 (min.) ; 3 (max.)	
response sensitivity		5 kOhm ... 150 kOhm adjustable	
max. voltage		10V AC (approx. 1 Hz)	
max. current		5mA	
min- /max- control		terminals 1, 2 und 3	
on- / off- control		terminals 1 und 3	
Output	terminals 7, 8 and 9	1 relay output (changeover contact) volt-free	
contact rating AC		250 V / 2 A // $\cos\phi > 0,7$	
contact rating DC		40 V / 2 A / resistance load	
delay time: energising / de-energising		approx. 1s / approx. 1s	
switch S1		I open circuit current II closed circuit current	
Transfer characteristics			
switching frequency		≤ 10 Hz	
Galvanic isolation			
power supply / output		galvanic isolation	
power supply / input		to DIN 106	
nput / output		rated insulation voltage 253 Veff	
Environmental conditions			
operating temperature		-25 °C ... +65 °C	
type of protection		IP 20	
Mechanical data			
design		modular terminal housing in Makrolon, flammability class UL94: V - 0	
mounting		snap/clip onto standard 35 mm rail or screw mounted via 2 screws	
connection terminals		self-opening instrument terminals max. 2.5 mm ²	
weight		approx. 110 g	

Electrode

KSR Suspension Electrode
Type: HV - L 100 - 3
atm., 80 °C

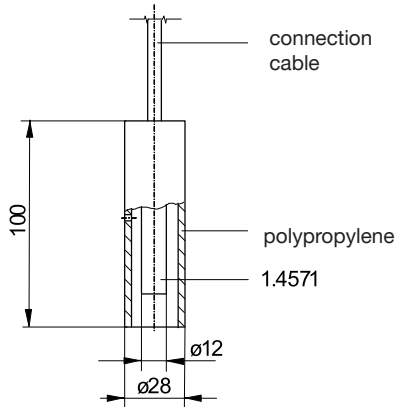

KSR Suspension Electrode
Type: HV 2 - L 45 - 2
atm., 80 °C

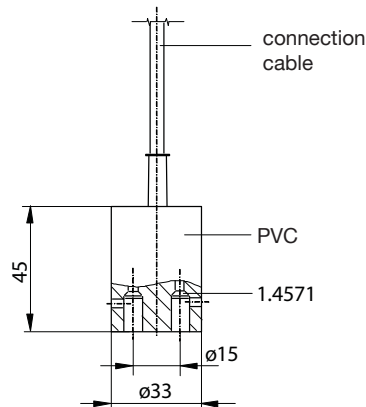

KSR Rod Electrode
Typ: ERK 1/2 - L.... - 3 Sil
6 bar, 100 °C

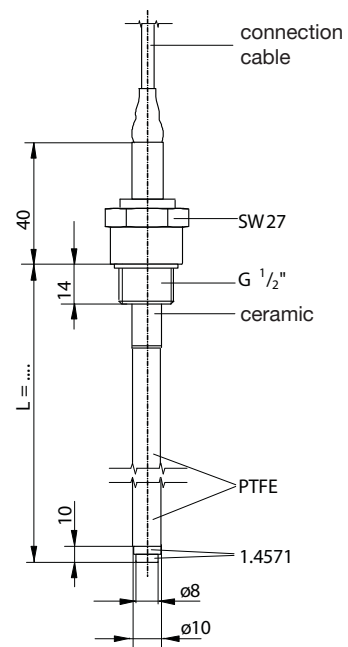

KSR Rod Electrode
Type: ERV 1/4 - L.... - 3 Sil atm.,
100 °C

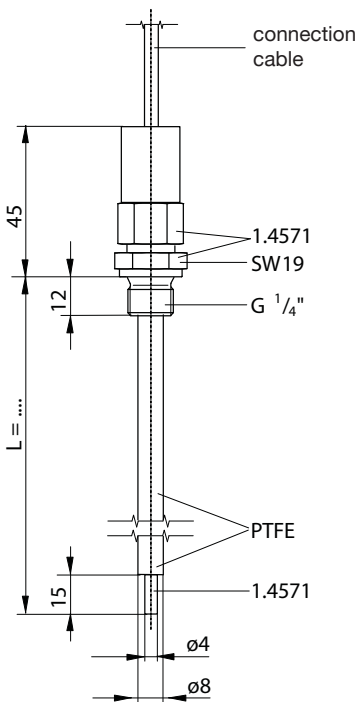

KSR Rod Electrode
Type: ERV 3/8 - L.... - 3 Sil
atm., 100 °C

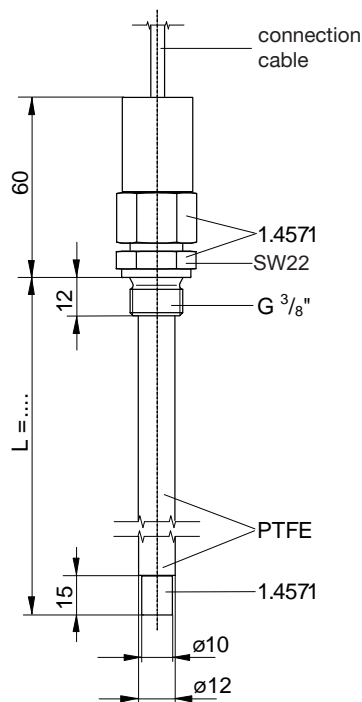

KSR Rod Electrode
Type: ERV 1/2 - L.... - 3 Sil - verst.
atm., 100 °C
Type: ERV 1/2 - L.... - ECTFE
- 3 Sil - adj. atm., 200 °C

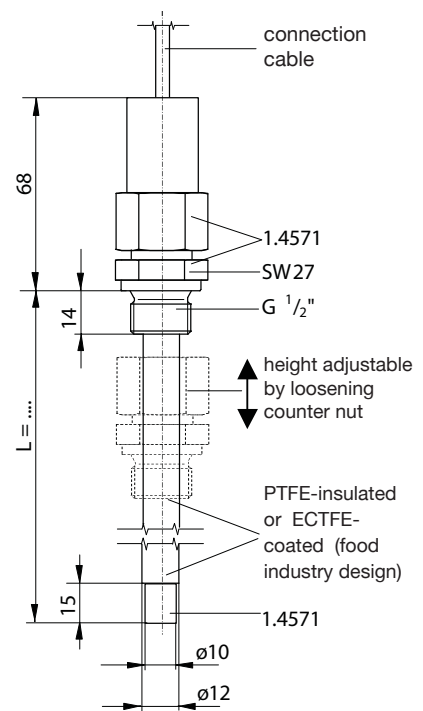

Electrode

KSR Rod Electrode Type:
ARK 1/2 - L.... 6 bar, 100 °C

aluminium terminal box
80 x 75 x 57 mm

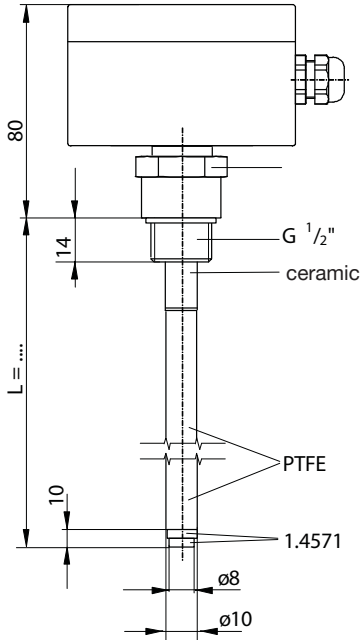

KSR Rod Electrode Type:
ARV 3/8 - L....

aluminium terminal box
64 x 58 x 34 mm

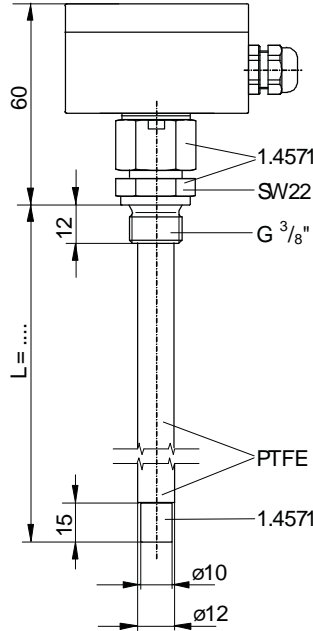

KSR Rod Electrode Type:
ARV 1/2 - L.... - verst. atm., 100 °C
ARV 1/2 - L.... - ECTFE- verst. atm., 200 °C

aluminium terminal box
64 x 58 x 34 mm

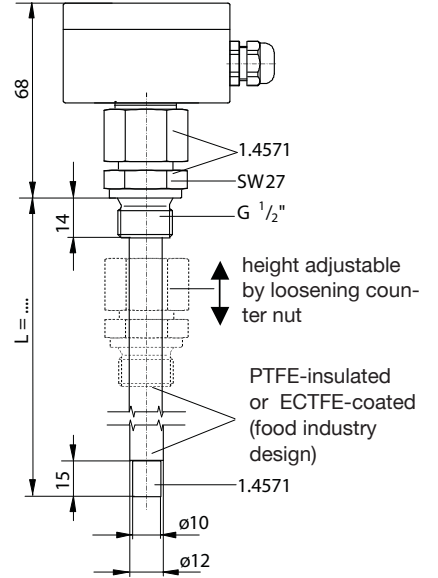

KSR Rod Electrode (max. length 1000 mm)
Type: APRPP2-V5-L1.../L2.../L3.../L4.../L5...
atm., 80 °C

polyester terminal box
80 x 75 x 55 mm

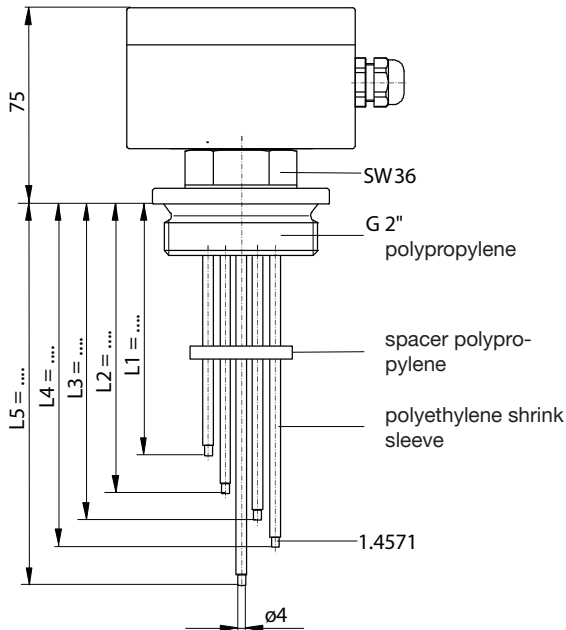

KSR Rod Electrode (length >1000 mm)
Type: APRPP2-V5-L1.../L2.../L3.../L4.../L5...
atm., 80 °C

polyester terminal box
80 x 75 x 55 mm

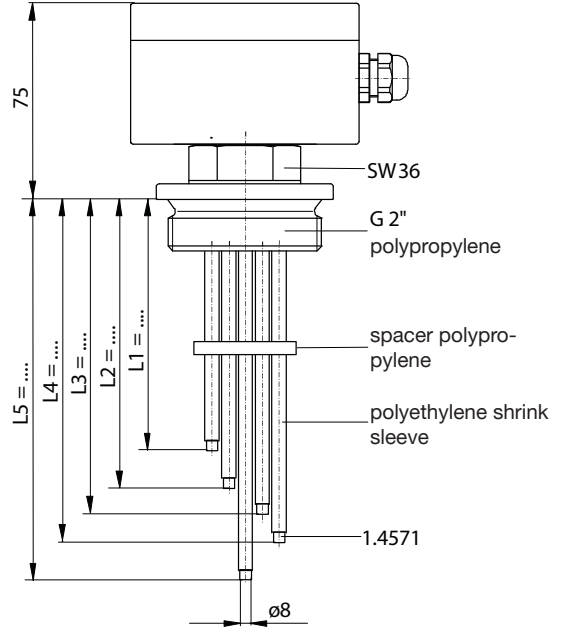

Water Detector Relay Type WW230 and WW24

General Description

KSR Water detector relays Type WW230 and WW24 operate on the conductive measurement principle. In conjunction with KSR Floor electrodes they can be used to monitor water ingress into rooms and areas caused by burst pipes or leaking vessels etc. The water detector relays provide an AC measuring voltage for the electrode circuit. Any number of floor electrodes can be connected to this to serve as detection points. As soon as electrically conductive liquids such as water, chemicals, alkaline or acidic solutions bridge one of the 2-pole floor electrodes, a small alternating current flows. The controllers are voltage and temperature stabilised and guarantee a defined switch behaviour. The signal delay is adjustable from between 0.5 s and 10 s and refers to the on/off switching of the output relays. The device is equipped with wire break (LB) monitoring (current free relay in event of failure). For this purpose an end-electrode (Type AFE) with built-in 430 kOhm resistor must be used. This function can be de-activated via a DIP switch. When utilising the LB (wire break) monitoring the second relay output serves as a fault

signal output. When LB (wire break) monitoring is de-activated the second relay output follows the first relay output.

Technical features

Open circuit current principle:

In the open circuit current principle the relay energises when the liquid bridges the 2-pole floor electrode.

Closed circuit current principle:

In the closed circuit current principle the relay energises immediately on power-up. It de-energises, when the 2-pole floor electrode is bridged by the liquid.

- Wire break monitoring (LB)
- open circuit current / closed circuit current – user selectable

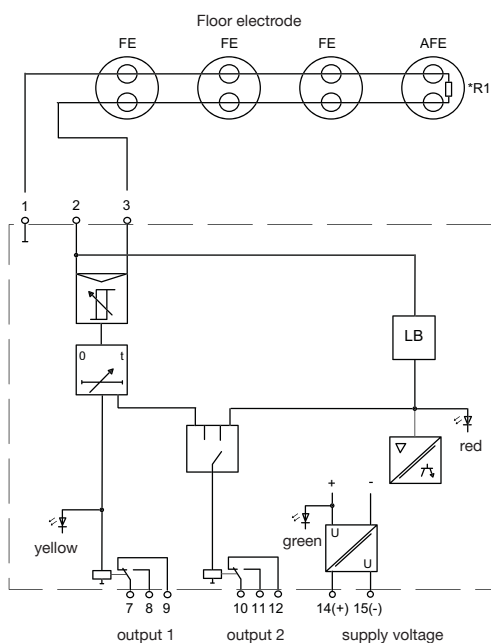

* resistor R1 = 430 kOhm required with activated wire break monitoring

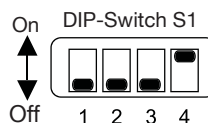

DIP Switch S1	Position	Function
DIP Switch 1	Off	Open circuit current
	On	Closed circuit current
DIP Switch 2	Off	LB deactivated
	On	LB activated
DIP Switch 3	DIP Switch 4	Energised and de-energised delay
Off	Off	0,5 s
Off	On	2 s
On	Off	5 s
On	On	10 s

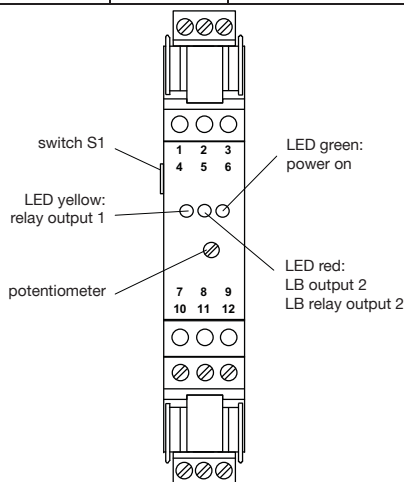

Water Detector Relay

Type WW230 and WW24

Technical data		WW230	WW24
Supply			
supply voltage	terminals 14(+), 15(-)	230 V AC, 48 Hz ... 62 Hz	20 V DC ... 30 V DC
power consumption		≤ 1,2 W	≤ 1,2 W
Input/control circuit	terminals 1 und 3		
response sensitivity		1 kOhm ... 150 kOhm adjustable	
max. voltage		10 V	
max. current		2,5 mA	
max. power		6 mW	
max. inductance L _o		100 mH	
max. capacitance C _o		3 μF	
max. L/R-relation		5 mH/Ω	
Output	terminals 7, 8, 9 ; 10, 11, 12		
contact rating AC		1 relay output (changeover contact) per output terminal set, volt-free	
contact rating DC		253 V / 2 A / cosφ > 0,7	
delay time: energising / de-energising (DIP-Switch 3 & 4)		0,5 s, 2 s, 5 s, 10 s	
open circuit / closed circuit current (DIP-Switch 1)		„On“ open circuit current	
		„Off“ closed circuit current	
		„On“ LB activated	
		„Off“ LB de-activated	
wire break (LB) monitoring (DIP-Switch 2)			
Transfer characteristics			
switching frequency		≤ 10 Hz	
Galvanic isolation			
power supply / output		galvanic isolation	
power supply / input		to DIN 106	
input / output		rated insulation voltage 253 V _{eff}	
Environmental conditions			
operating temperature		-25 °C ... +65 °C	
type of protection		IP 20	
Mechanical data			
design		modular terminal housing in Makrolon	
		flammability class UL94: V - 0	
		snap/clip onto standard 35 mm rail	
		or screw mounted via 2 screws	
		self-opening instrument terminals max. 2.5 mm ²	
		approx. 110 g	
type of protection			
connection terminals			
weight			

Floor Electrodes

Type coding	FE - grey housing AFE - red housing with built-in resistor 420 kOhm
housing material	PVC
electrode material	CrNi-Stahl 1.4571
distance electrode to floor	1 mm
max. permissible ambient temperature	-40 °C ... + 60 °C

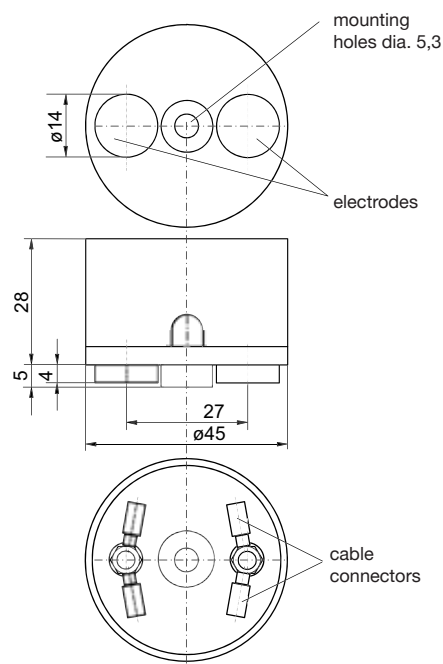

Modifications may take place and materials specified may be replaced by others without prior notice.
Specifications and dimensions given in this leaflet represent the state of engineering at the time of printing.



KSR KUEBLER Niveau-Messtechnik AG
Heinrich-Kuebler-Platz 1
69439 Zwingenberg, Germany
Tel. (+49) 6262 87-0
Fax (+49) 6263 8799
E-Mail info@ksr-kuebler.com
www.ksr-kuebler.com